

General Description

BP3337E is a high PF PSR constant current LED driver with high current accuracy. It is suitable for 90Vac-277Vac universal input.

BP3337E achieve high PF by constant on time control. With internal THD optimizer, the THD of input current can be further reduced. BP3337E works in BCM mode, which can help to improve switching loss and EMC performance.

BP3337E adopts DIP-7 package.

Features

- 90-277Vac universal input
- High PF low THD (PF>0.9, THD<15%)
- Support two-winding design for isolated application
- High accuracy of current reference (+/-3%)
- Good line and load regulation
- Critical conduction mode
- Low operation current
- VCC UVLO
- Cycle by cycle current limitation
- Output open/short protection
- Thermal fold back
- DIP-7 package

Applications

- LED Driver
- High-Performance LED Fixture

Typical Application

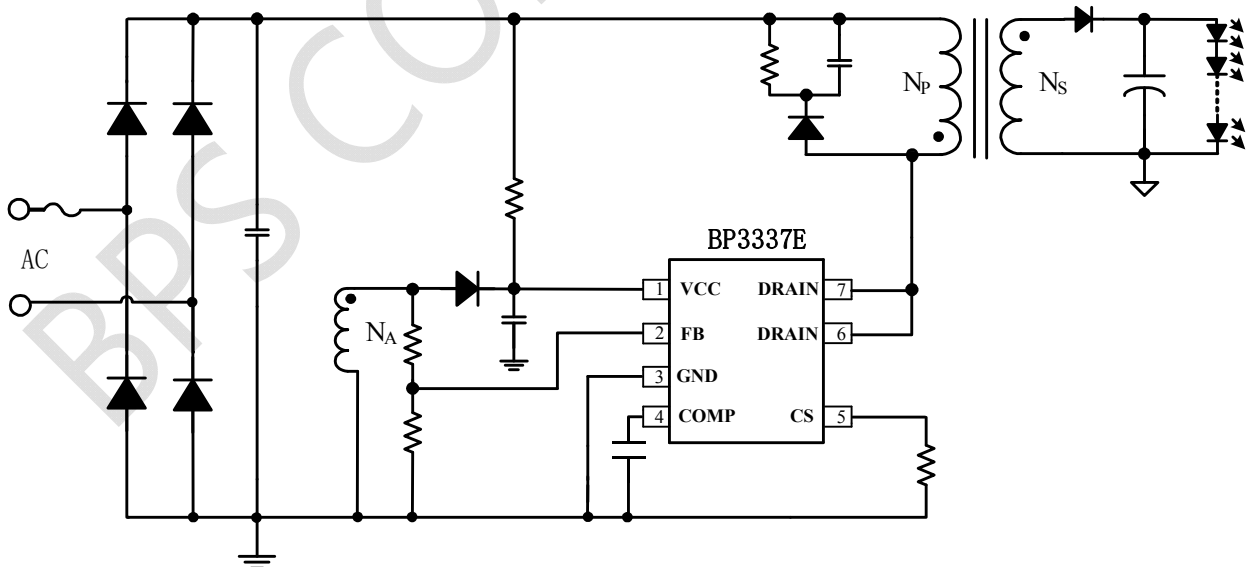

Fig. 1 Typical Schematic Diagram

Ordering Information

Part Number	Package	Operating Temperature	Packing	Marking
BP3337E	DIP-7	-40 °C to 105 °C	50 pcs./Tube	BP3337E XXXXXYZ XXYYWWZ

Pin Configuration and Marking

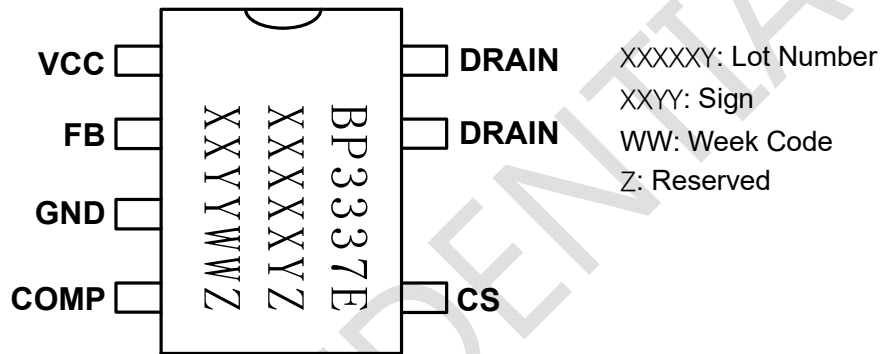

Fig. 2 Pin Configuration

Pin Definition

Pin No.	Name	Description
1	VCC	Power supply for IC
2	FB	ZCD detection and input/output voltage detection
3	GND	IC ground
4	COMP	Loop compensation
5	CS	Primary side current sense, connected with sense resistor
6	DRAIN	DRAIN of internal MOSFET
7	DRAIN	DRAIN of internal MOSFET

Disclaimer

The information provided in this datasheet is believed to be accurate and reliable. However, Bright Power Semiconductor (BPS) reserves the right to make changes at any time without prior notice.

No license, to any intellectual property right owned by BPS or any other third party, is granted under this document. BPS provides information in this datasheet “AS IS” and with all faults, and makes no warranty, express or implied, including but not limited to, the accuracy of the information provided in this datasheet, merchantability, fitness of a specific purpose, or non-infringement of intellectual property rights of BPS or any other third party. BPS disclaims any and all liabilities arising out of this datasheet or use of this datasheet, including without limitation consequential or incidental damages.

BPS Confidential